

Step 1: milling

BioKey Core Size: 36 x 47 x 29 mm (width x height x depth). Milling Size: >37x48x35 mm, **just one Milling** is necessary, construction height: > 120cm, stainless steel panel: 44,6x75,4 x 1.5mm. Screw (2x, Type: C2.9x22H, distance: 61 mm).

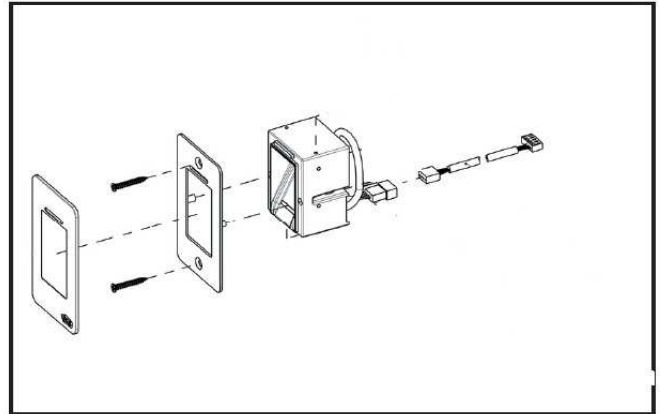
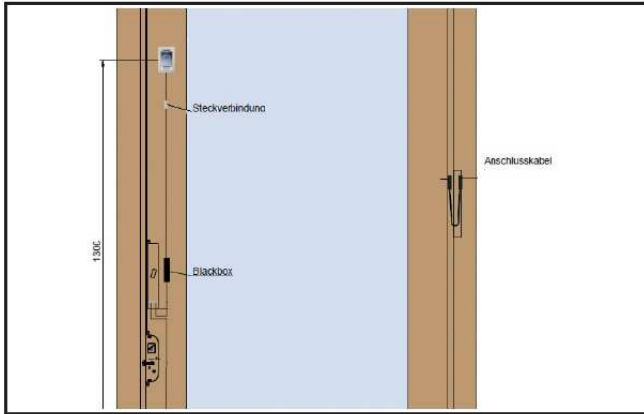

Step 2: cabling

Cabeling in the door, to use just for manufacturer

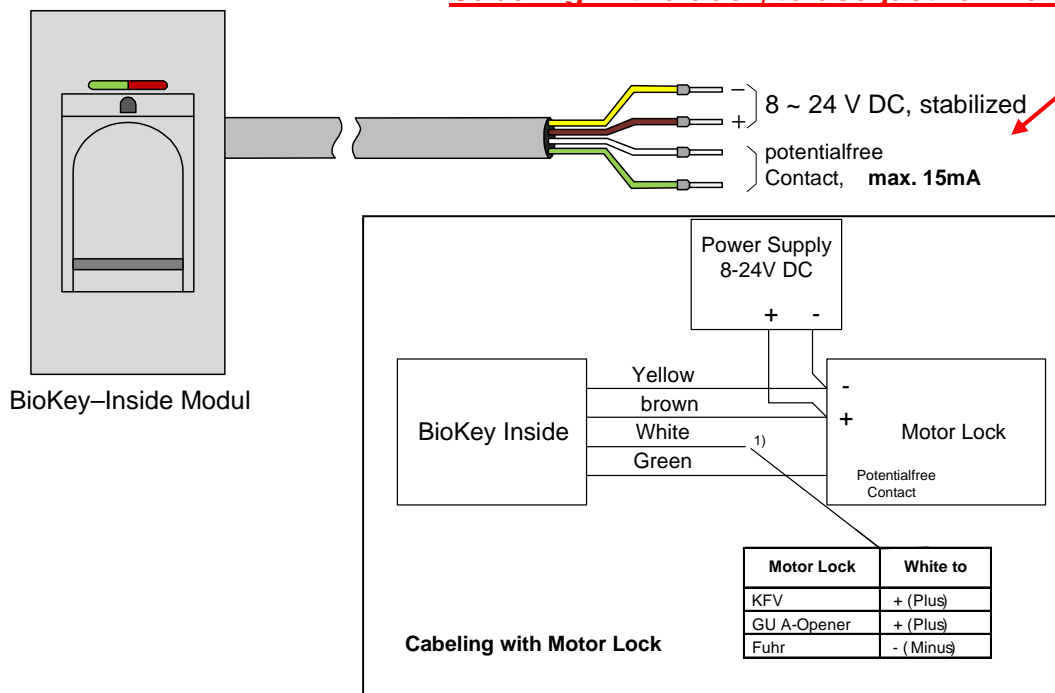

Step 3: Autotest

To test the functionalities (without Fingerprints) with the IR-Keypad: **0 OK** . If OK, green/red LEDs glow constantly (after about 10s).



DESIGN PLUS
powered by light building

